

# Electronic Access Cabinets

2110 East Walton Blvd., Ste. F • Auburn Hills, MI 48326 • Phone (888) 884.LEID (5343) • Fax (248) 364.3371 • [www.LEIDProducts.com](http://www.LEIDProducts.com)

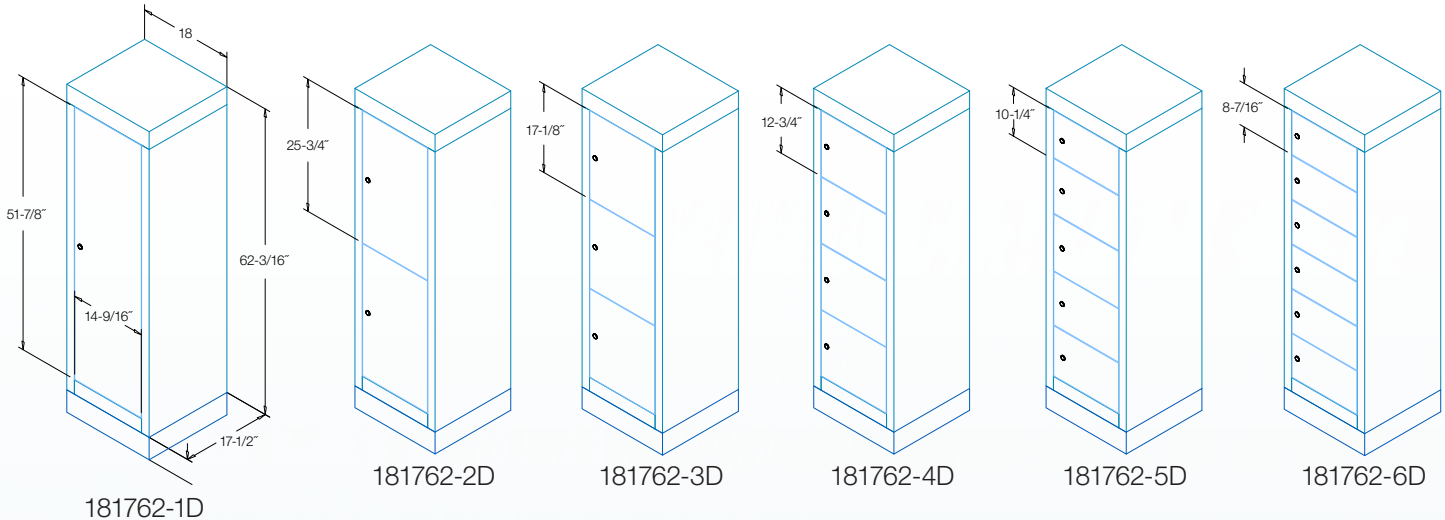

## Access

- Electronic e-latch locks on front doors
- Keypad-LCD using pass code with optional card reader
- Biometric access with computer kiosk

## Cabinets

- All steel construction
- 16-GA sides, shelves & frame
- 20-GA wireways, top & back
- Welded frame with riveted assembly

## Doors

- 16-GA steel
- Electronic e-latch locks on doors
- Spring-loaded front doors automatically open when unit is accessed
- Key override on doors
- Optional rear door for pass-through installation - key cam lock

## Finish

- Powder-coated steel

## Installation/Electronics

- Each separate location requires a controller with max operating capacity up to 8 units
- 120V AC input / 15amp circuit (lead unit with controller)
- Controller and expansion hub located in top of unit
- Units can be installed individually or daisy chained (side by side)
- Power cord and Ethernet exit bottom left of the lead unit (-4 feet)
- Units requires secure attachment to wall or floor and unit in multiple installation must be secured to each other
- Optional 12" base

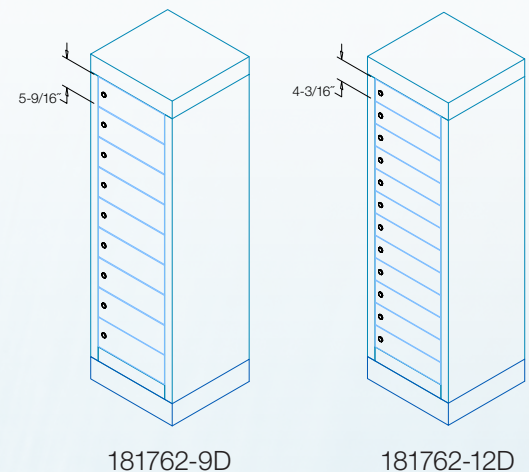

## Dimensions

- Overall unit measurement 18" W x 17-1/2" D x 62-3/16" H
- Inside unit depth – front load 16" D / rear load 15" D